

Modular, stainless steel conveyors

DELIVERING PRODUCTIVITY AND COST CONTROL

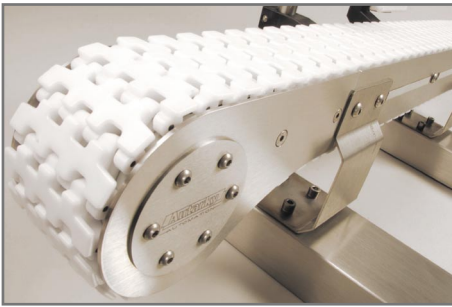

High speed
low noise
easy to maintain

Our modular stainless steel conveying systems have been developed to meet the demanding requirements of specialised applications in sectors ranging from food and beverage to pharmaceuticals and from healthcare to electronics.

Modular stainless steel conveying systems can be designed and built quickly and efficiently; just as importantly, they are easy to extend or modify as the needs of your production or goods handling operations change. In addition, these systems are simple to maintain and use proven drive and chain technology for optimum performance and reliability.

Each system uses the advanced Stretch Line chain technology from our business partner, Schüco Design.

Stretch Line is flexible, tough and lightweight, has a high load capacity and can run at speeds of up to 80m/minute, yet cuts chain noise by almost 50%; additionally, the unique construction eliminates trap points to improve operator safety still further.

Our modular stainless steel conveyor systems are backed by comprehensive UK system design, development and engineering services. We can supply pre-configured conveyor modules, or carry out a complete design, installation and commissioning project, with the option of long term maintenance contracts.

www.autarky.com

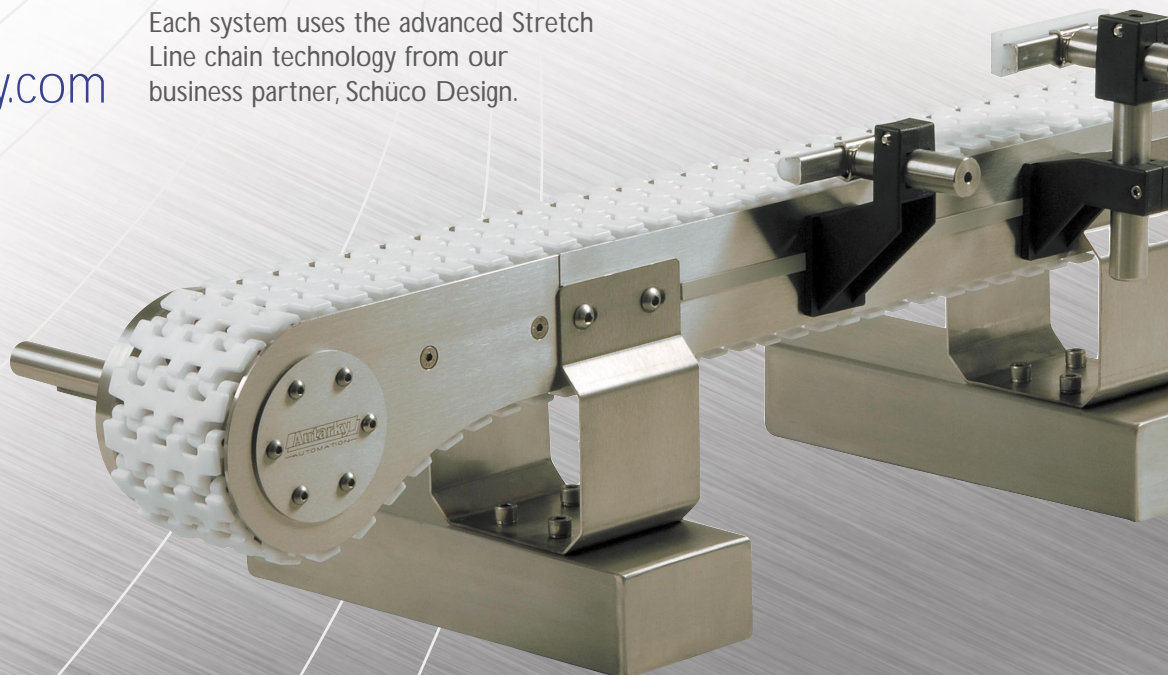

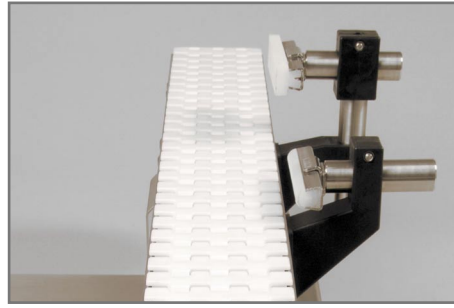

Key technical specification

Our modular stainless steel conveyors systems feature proven technology and are backed by full service and support. They are available in a wide range of sizes and configurations.

		CS065SL	CS090SL	CS200SL
Design width/chain width	Mm	65/62	90/87	200/194
Product width	Mm	15-140	20-200	100-400
Maximum product weight Horizontal/Vertical	Kg	10/5	10/5	15/5
Maximum load Conveyor system/chain link	Kg	150/1.5	150/1.5	200/1.5
Maximum conveying speed	m/min	80	80	60
Maximum line length/vertical clamp conveyor	m	30/8	30/8	30/-

Typical applications

Modular stainless steel conveyors can be used in a wide range of demanding applications. These include:

- Processing, packaging and labelling of wrapped foods
- Assembly operations for medical goods
- Handling of pharmaceuticals and drug products
- Manufacture of electronic components (anti-static)
- Production of specialised optical, filter or instrumentation products

Stainless steel conveyors are also available for

- Slatband: indexing
- Modular belt: accumulating
- Belt: gripper
- Case chain: incline/decline
- Roller: variable speed



Autarky Automation Limited

Charlwoods Place, Charlwoods Industrial Estate,
East Grinstead, West Sussex RH19 2HY

Tel: +44 (0)1342 311388 Fax: +44(0)1342 323733

Email: sales@autarky.com www.autarky.com